

## FATEK FBs-PLC Ladder Program Programming Software

### ■ General Feature

- Windows based application program, all the operating follow the convention of windows environment, easy for learning and operating. No matter beginner or Pro can operate with great efficient.
- Adopt project concept, which category the whole tasks of program to be developed with hierarchy tree. Through the visual effect the user can see through the whole project at first glance. No matter at program or maintenance stage all the jobs need to do can perform with intuitive.
- Thoughtful and considerate entry method design, incorporate both the keyboard and mouse for entry device. No matter at field site or office environment can operate with ease and efficient.
- Provides the connection for PLC and PC with varieties. Among the connections, there are hardware connection, Modem connection and Internet connection. For every different connection, WinProladder provide a session name to associate the setting of the communication parameters, such as port no., baud rate, IP address, phone number, etc.. With this feature can alleviate the user from the burden of the memorizing.

### WinProladder

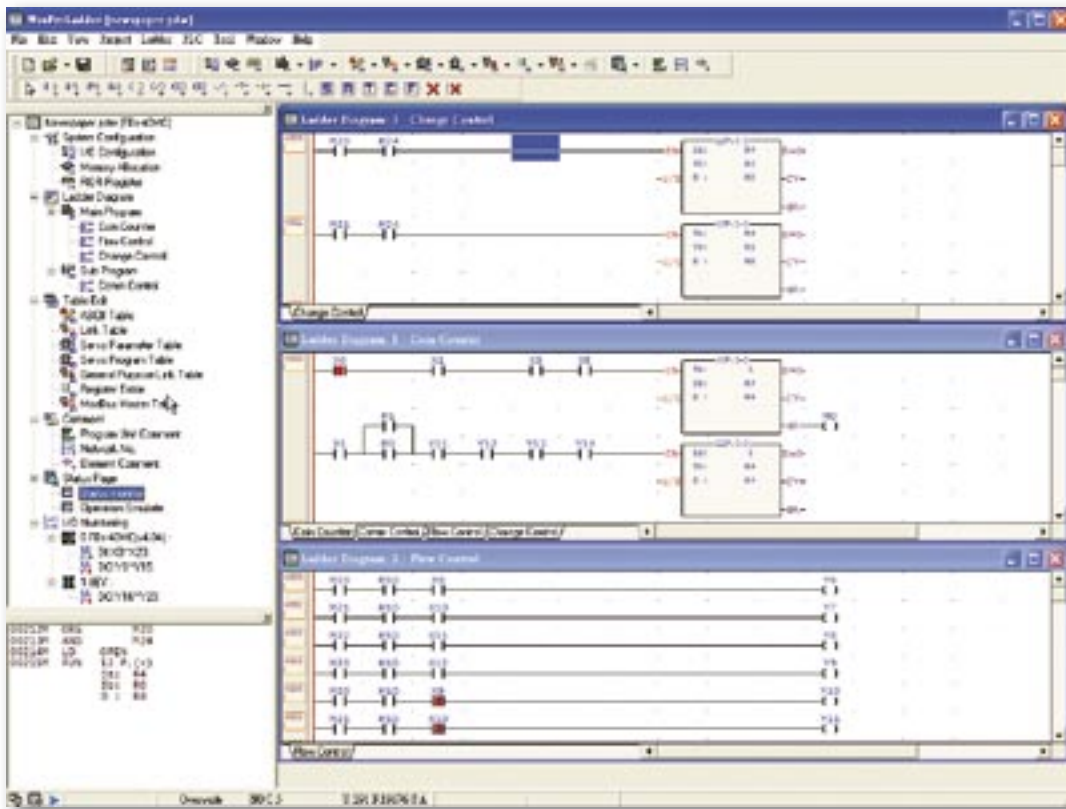

### ■ Program editing

- Provides the on-line program editing capability. After modify the ladder program can send the RUN command immediately without to re-download the program to PLC. With this feature can reduce the application development time dramatically comparing with other PLC without this feature.
- Ladder program can be edited without stop the PLC from running (Run time editing).
- Multiple ladder program windows, can show different fragmentation of ladder program at one time and perform the copy, paste and compare operation between these windows.
- Provides the flexible ladder network editing capability. With the help of copy, paste and delete highly efficient operation can complete a complex program with few keystrokes.
- Provides the capability to divide the whole program into many program units. User can at will partition the whole development task into many independent program units according to the functionality or other classify methodology and perform the entry, editing, testing and documentation independently. With this feature can greatly ease the maintenance of the whole application.
- Provides an individual window for mnemonic instruction display. Immediately display the equivalent mnemonic code corresponding to the ladder network pointed by the cursor.
- Provides the flexible program search capability, can search contact, register or function. Also can set a filter to narrow down the search object to ease the user from picking up the desire results among the whole bunches of search result. Most of all, just double click the interested message line can bring out the corresponding ladder program to the user.
- Provides a powerful syntax check tool. With this tool can parse the user's program and generate a parsing message in one window. In this window all the warning or error messages regard the program will be listed line by line. User just double click the interested line then the ladder program will be shown on the window with the cursor stay on the question part.

## ■ Program testing

- Provides multiple pages of status monitoring. User can monitor and modify the status of discrete contacts and registers on the status page. Each discrete input and output (include the internal relay) can be disabled and forced on or off. Each register can be selected individually to show with different format such as hexadecimal, decimal and binary. Best of all, all the layout of the status pages can be stored in the project and there is no need for user to re-define the page each time when he/she wants to monitor the status.
- Multiple high lighted ladder program display windows. The conducting condition of each contact element can be revealed by the color of the element drawing. The register value embedded with the function block also can be shown currently with ladder diagram. The discrete element can be easily disabled and forced on or off directly from the ladder diagram.

## ■ Program documentation

- Provides discrete element, register, network, and program unit and project comment. Besides the project comment all other comments can be displayed with ladder diagram. With this feature the user can easily realize how the ladder program is working.
- Provides following report printout function:  
Ladder diagram printout can select the scope and detail level of the ladder diagram for different kind of reporting requirements. Used ladder element cross-reference report can list the statistics of all ladder elements used in the project.
- The comment of the contact and register can be created by this software or by using text editor that were familiar with user. Comments can be imported from the text file and also can be exported to the application software such as Excel for further processing.
- The network of ladder program can be copied to other editing software such as Word by using copy and paste function. With this feature, can facilitate the documentation of program when use the editing software.

## ■ Project oriented program

Adopt project concept, which category the whole tasks of program to be developed with hierarchy tree. Through the visual effect the user can see through the whole project at first glance. No matter at program or maintenance stage all the jobs need to do can be performed with intuitive.

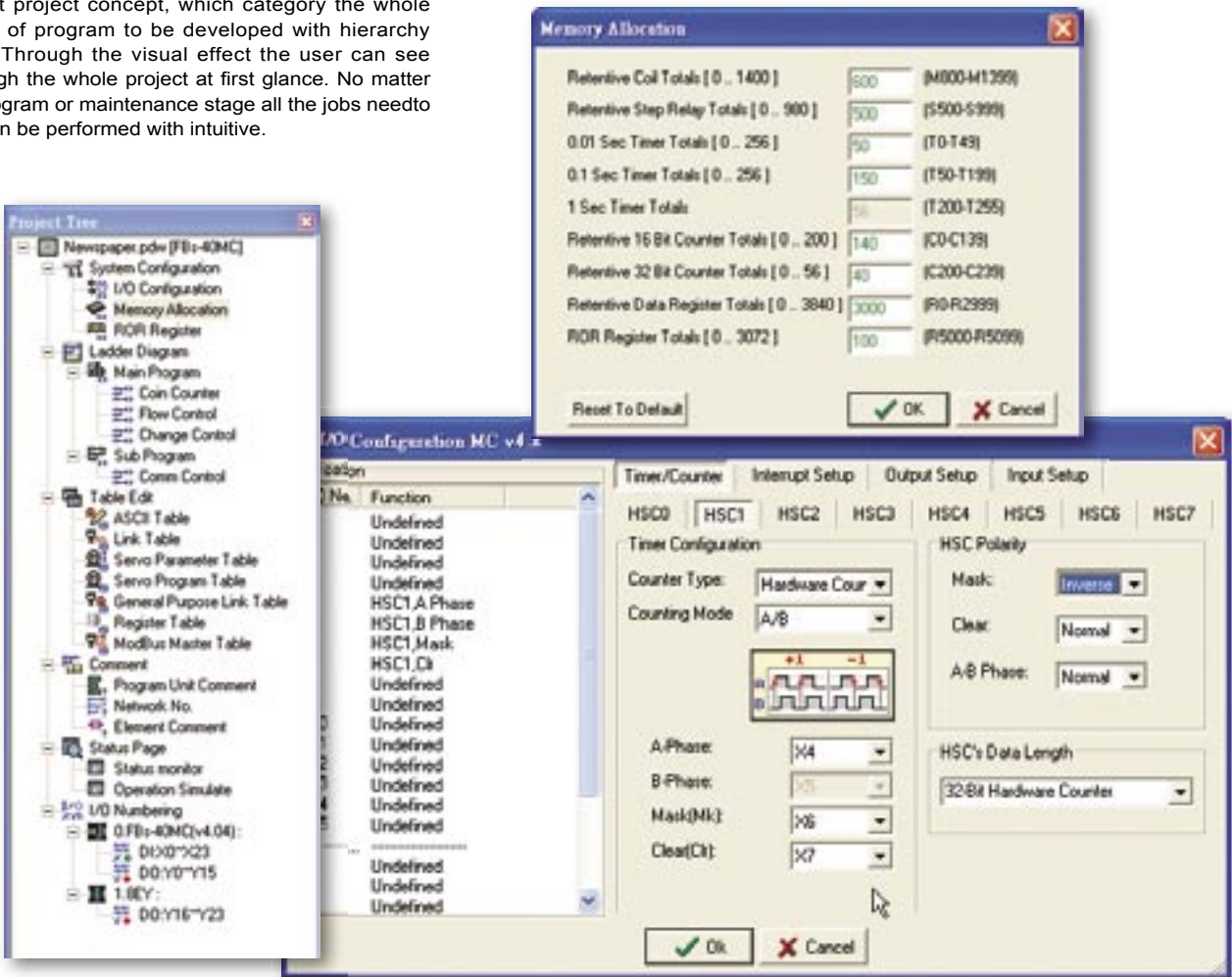

**WinProladder software package**

**■ Ladder program editing screen**

Multiple ladder windows, can perform the network copy, paste, cut and compare operations among windows.

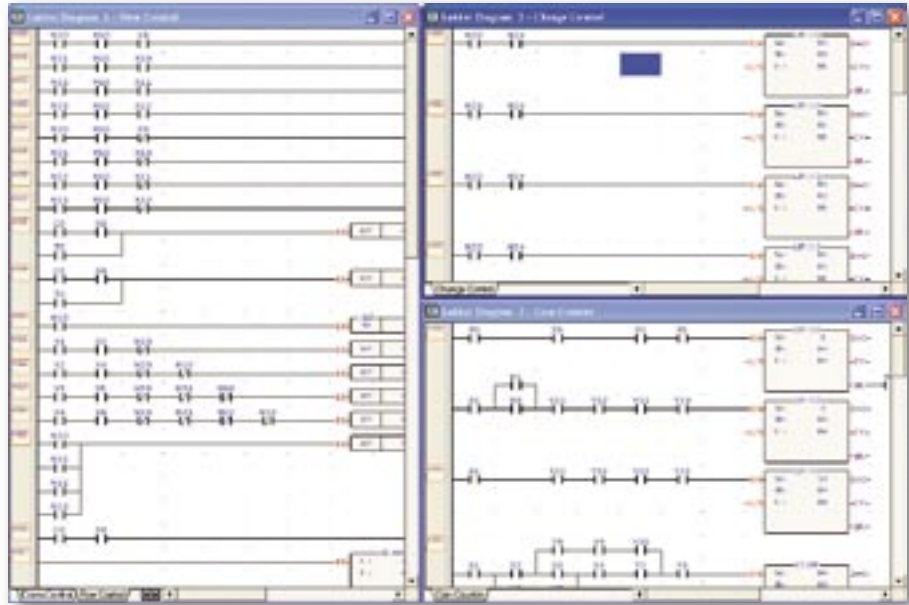

**■ Status monitor and control**

Multiple status page window, can define the elements, registers to be monitoring and assign its display format. The state of the contact elements can be disabled and forced. Register value also can be entered.

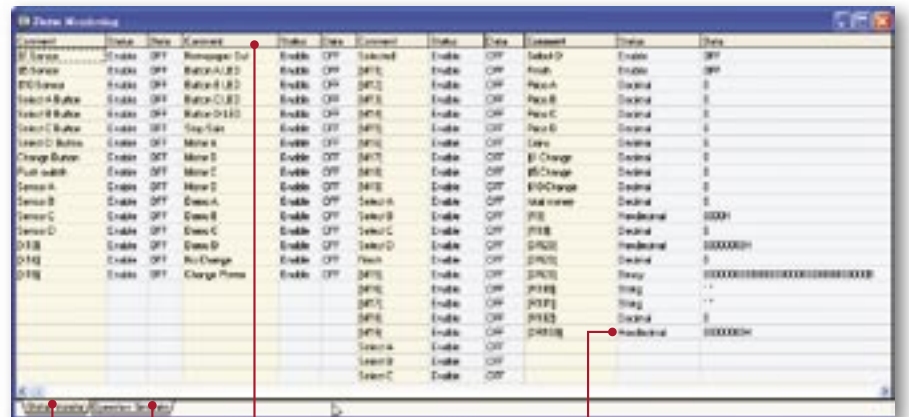

Multi-page status monitoring      Monitoring status with comment display      Display with different data formats

Multiple high lighted ladder program windows. The conducting condition of each contact element can be revealed by the color of the element drawing. The register value embedded with the function block also can be shown currently with ladder diagram.

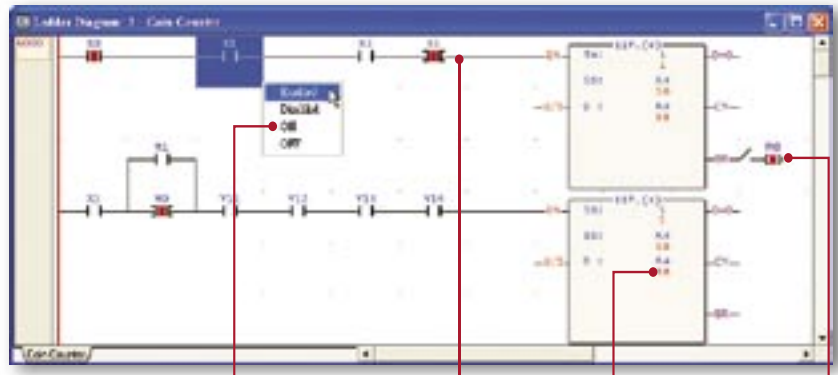

Control the contact status directly on ladder program screen      Conducting status of contact with disable indication      The live content of register can be shown directly on ladder diagram      Coil conducting status with disable indication

**■ Mnemonic ladder instruction display window**

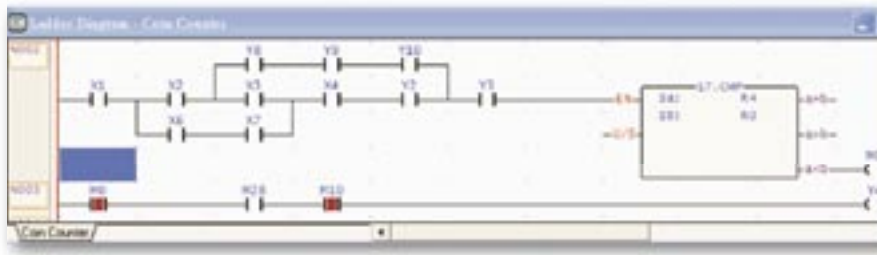

```

00013H GSK OPEN X1
00013H LD X1
00014H OUT TR 0 X2
00015H AND TR 0 X2
00016H ORLD
00017H OUT TR 1 X1
00018H AND TR 1 X1
00019H AND TR 1 X1
00020H AND Y10
00021H LD TR 1 X3
00022H AND X3
00023H LD TR 0 X4
00024H AND TR 0 X6
00025H AND X7
00026H ORLD
00027H OUT TR 2 X4
00028H AND X4
00029H AND Y2
00030H ORLD
00031H OUT TR 3
00032H AND TR 3
00033H LD TR 3 X5
00034H AND TR 3 X5
00035H LD TR 2 X3
00036H AND LD ...CMP
          S01: E4
          S01: E3
00038H PD 2
00039H OUT X0
    
```

Dedicate mnemonic instruction window can show the mnemonic instructions corresponding to the network pointed by the cursor. This feature can help the teaching of ladder programming by mnemonic instruction.

**■ Ladder diagram with comments**

Provides different detail level of comment for contact, register, network and program to facilitate the readability and maintenance of the program.

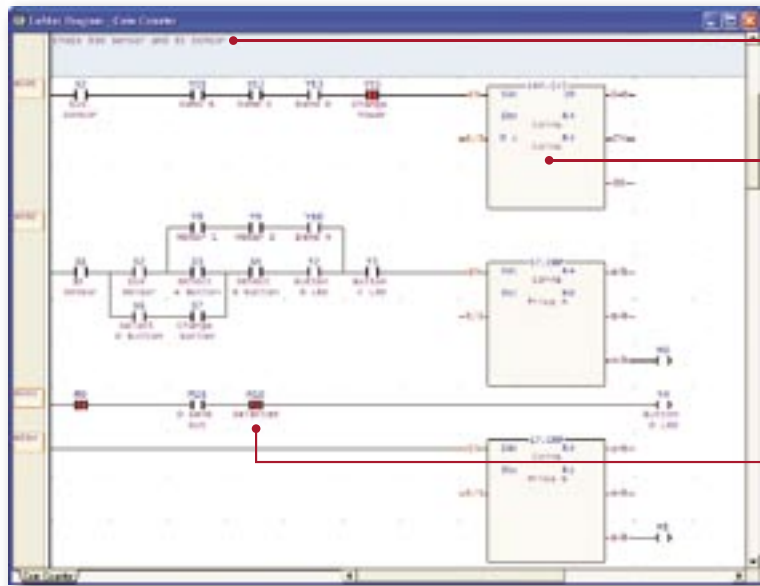

Network comment

Register comment

Digital element comment

**■ Element comment editing**

With element comment window, can attach an easy for memorizing comment to the elements, detail description also can be added to facilitate the maintenance of project.

Can choose all, used, unused elements for displaying to assist the user to input the comments

Ref. No.	Comment	Description
Y0	<input type="checkbox"/> All	On when all messages will use
Y1	<input type="checkbox"/> Used	On when entering use program
Y2	<input type="checkbox"/> Used	On when entering use program
Y3	<input type="checkbox"/> Used	On when entering use program
Y4	<input type="checkbox"/> Used	On when entering use program
Y5	<input type="checkbox"/> Stop Date	On when making machine malfunctions
Y6	<input type="checkbox"/> Motor A	On when M messages received
Y7	<input type="checkbox"/> Motor B	On when M2 messages received
Y8	<input type="checkbox"/> Motor C	On when M3 messages received
Y9	<input type="checkbox"/> Motor A	On when M4 messages received
Y10	<input type="checkbox"/> Device B	
Y11	<input type="checkbox"/> Device C	
Y12	<input type="checkbox"/> Device D	
Y13	<input type="checkbox"/> No Change	
Y14	<input type="checkbox"/> No Change	
Y15	<input type="checkbox"/> Change Point	

The comment, through exporting and importing can be integrated with other application software.



## FP-07C handheld programming panel

### ■ FP-07C handheld programming panel

Features:

- Easy to use and portable, with program editing, copying, status monitoring and debugging functions, most suitable for field maintenance.
- Change working mode only by a single keystroke, without having tedious exit process from current working mode.
- Adopt super capacitor to keep program and data when power lose, convenient for loading data and register from multiple PLCs.



Item		Specification
Power consumption		5V/100mA
Keyboard		48 silicon rubber keys
Display		16x2 dot matrix LCD
Communication port		RS232 serial communication port
Data retention	Method	Kept by super capacitor
	Retention time	At least 7 days
Dimension		Figure 6

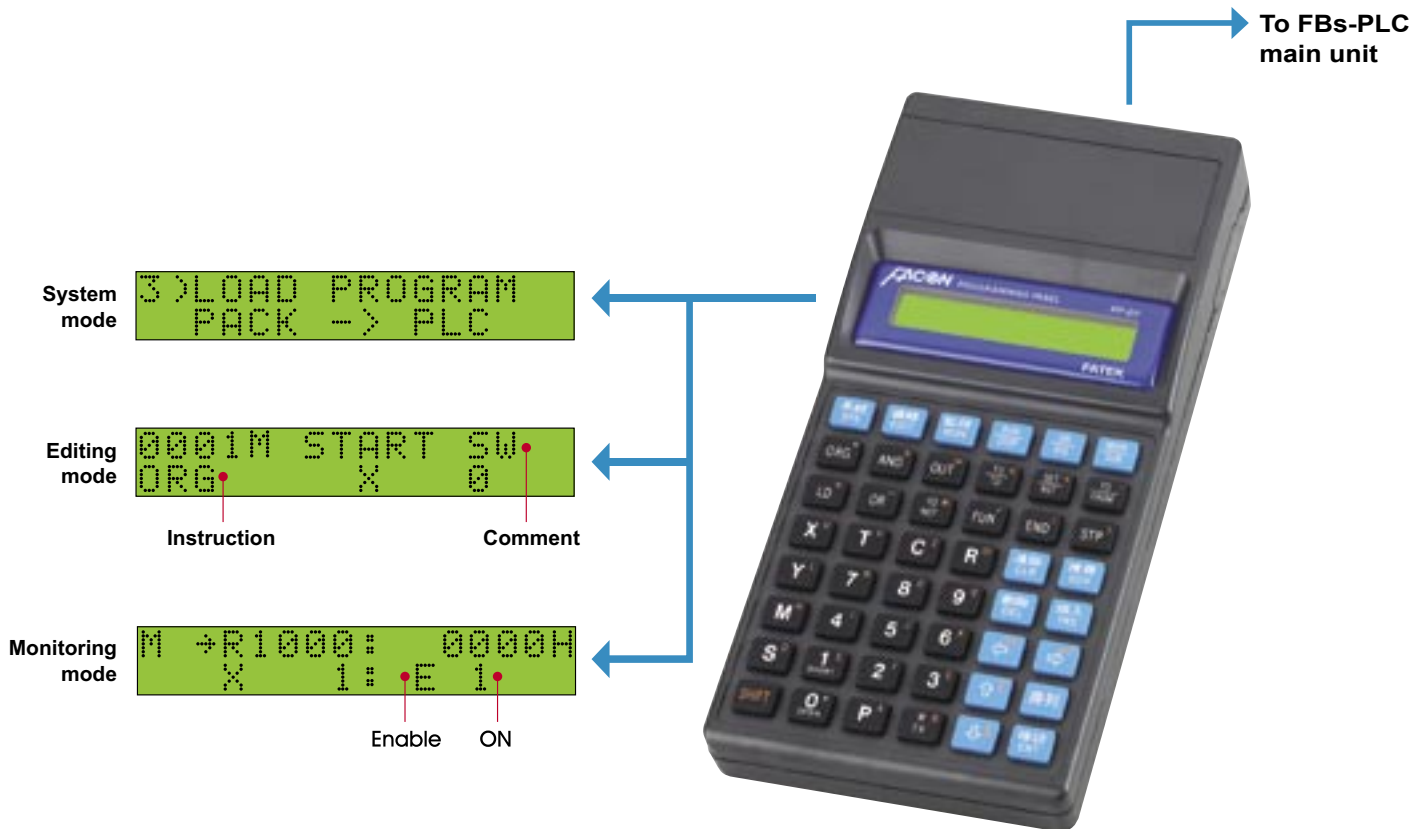

## ■ Features:

- It contains the basic items required by PLC digital I/O training, such as the FBs-24MCT highly functional main unit, the FBs-CM25E Ethernet module, digital input socket, simulated switches, and digital output socket. Also included in the same kit are advanced application peripherals like encoder and stepping motor (coupled with belt for transmission), seven segment display, 10 large-diameter (10mm) LED indicators, thumbwheel switches, and keyboard. It greatly reduces the time and manpower used in wiring and resource management of teaching.
- The built-in RS232, RS485 and the Ethernet three ports (can be expanded to five with communication boards) not only enable the teacher's computer to connect with the training kits of all students to conduct networking on-line teaching such as loading, monitoring, modifying, and storing, but also can be used in advanced course such as computer connection, intelligent ASCII peripherals as well.
- A special designed software "WinProladder teaching assistant" can let instructor download or upload ladder program to or from the PLC of the whole class or individual through computer. Instructor also can perform monitoring, instruction and modification, and collect and save student's homework periodically with "WinProladder teaching assistant". The teaching software is especially suitable for examination and contest and is the best choice for network teaching.
- PLC output is isolated by the relay with socket and fuse and then output to terminal. These isolations can prevent PLC from damaging caused by incorrect wiring and easy for repair and replacement.

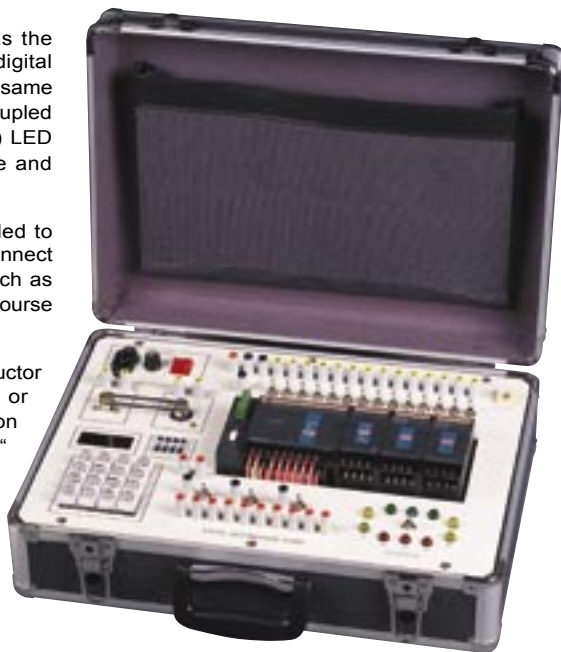

FBs-TBOX

Item		Description	
<b>Case</b>		Aluminum suitcase. Dimension is 46x32x16cm. Top cover and box body can be separated.	
<b>Power supply</b>		100~240VAC / 2A fuse / power switch with indicator	
<b>PLC</b>		FBs-24MCT(transistor output)+FBs-CM25E(Ethernet communication module)	
<b>Programming tool</b>	<b>Programmer</b>	FP-07C handheld programming panel, can develop program, monitor (optional)	
	<b>Winproladder Programming Software</b>	Instructor site: Standard WinProladder with 'teaching assistant' utility Student site: Standard WinProladder	
<b>Communication interface</b>	<b>Built-in</b>	Port0	RS232, Mini-Din connector
		Port1	RS232 or RS485 selectable, directly mounted on FBs-24MCT main unit
	Port2		
	<b>Communication board(CB) (optional)</b>	Port3	RS232, standard DB-9F connector
		Port4	RS485, 3-pin European terminal block
(Port4)		Ethernet 10BaseT, IEEE 802.3 standard. Use port4 to interface PLC main unit	
<b>Input interface</b>		Banana terminal and simulation switch with automatic and manual reset functions	
<b>Output interface</b>		Banana terminal, 10 points. Transistor output(Y0~Y9). All outputs buffer with discrete relay before come to terminal. Y0 and Y1 also provide a direct output terminal for high-speed pulse output (HSPSO) application.	
<b>Expansion module (optional)</b>		Secured by DIN Rail, 12.5cm wide slot, can accommodate three 4cm thin modules or other modules with equivalent width	
<b>Application peripheral</b>	<b>Display module</b>	4 digits 7-segment display module · attached with BCD decoding circuit	
	<b>Thumbwheel switch</b>	4 digits BCD thumbwheel switch module	
	<b>Keyboard module</b>	4 x 4 matrix keyboard module ( Wiring coordinate with convenient instruction )	
	<b>Encoder</b>	Power supply 24VDC · 200P/R · open collector · A/B phase	
	<b>Stepping motor</b>	CK/DIR control · 200P/R	
	<b>LED display</b>	10 of 10mmØ high-brightness LED (in red, yellow, and green), driven individually by Y0 to Y9	
<b>Number of linked stations</b>		Maximum 254 stations (1 station for instructor, 253 stations for student)	

Figure 1

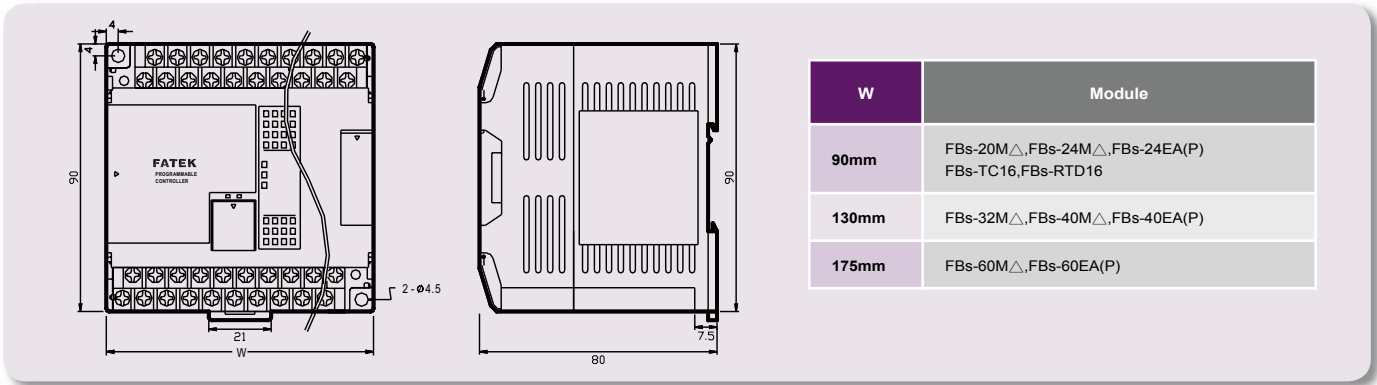

Figure 2

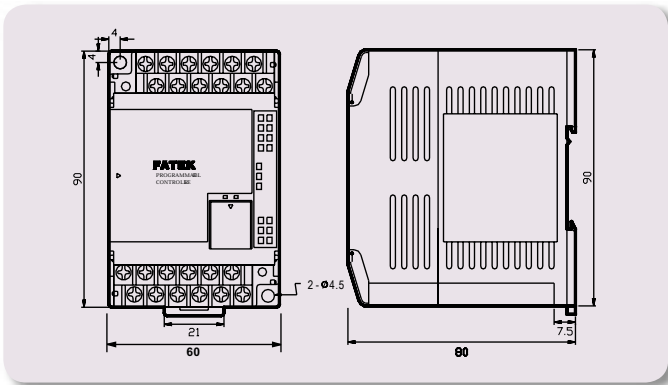

Figure 3

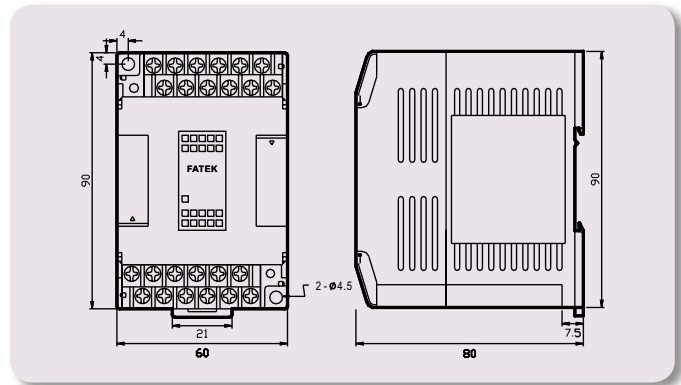

Figure 4

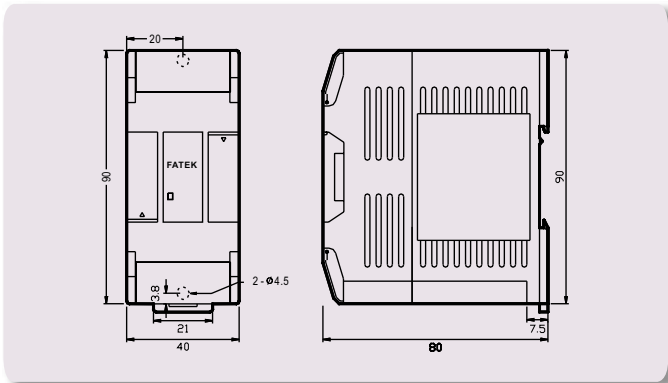

Figure 5

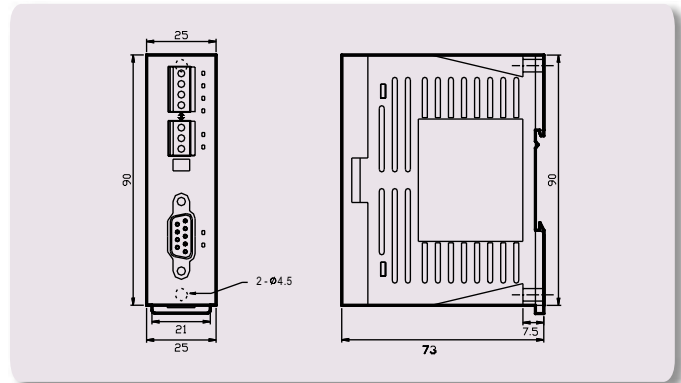

Figure 6

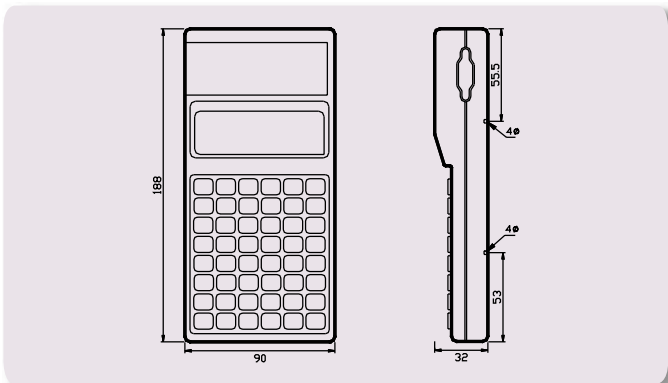

Figure 7

